

14. CONTINENTAL EUROPE

ITEM	PAGE
14.1 European Union (EU) Standards	
14.1.1 CENELEC	232
14.1.2 CENELEC Cable Identification	234
14.1.3 CENELEC Color Codes	236
14.1.4 CENELEC Copper Conductors	237
14.1.5 CEN	240
14.1.6 Supply Voltages and Plug Configurations	240
14.2 Austrian Standards	
14.2.1 ÖVE	241
14.2.2 Supply Voltage and Plug Configuration	241
14.3 Belgian Standards	
14.3.1 CEBEC	242
14.3.2 IBN/NBT	242
14.3.3 Supply Voltages and Plug Configurations	243
14.4 Danish Standards	
14.4.1 DEMKO	244
14.4.2 Supply Voltage and Plug Configuration	244
14.5 French Standards	
14.5.1 UTE	245
14.5.2 AFN	245
14.5.3 CIGRE	245
14.5.4 CNET	245
14.5.5 Supply Voltages and Plug Configurations	245
14.6 German Standards	
14.6.1 DIN	247
14.6.2 VDE	248
14.6.3 DKE	249
14.6.4 Supply Voltages and Plug Configurations	249

14. CONTINENTAL EUROPE (CONT)

ITEM	PAGE
14.7 Irish Standards	
14.7.1 NSAI	250
14.7.2 Supply Voltage and Plug Configurations	250
14.8 Italian Standards	
14.8.1 IMQ	251
14.8.2 CEI	251
14.8.3 CESI	251
14.8.4 UNEL	251
14.8.5 Supply Voltage and Plug Configurations	252
14.9 Dutch Standards	
14.9.1 KEMA	252
14.9.2 NEC	253
14.9.3 Supply Voltage and Plug Configurations	253
14.10 Norwegian Standards	
14.10.1 NEMKO	254
14.10.2 NTRA	254
14.10.3 Supply Voltage and Plug Configurations	254
14.11 Portuguese Standards	
14.11.1 IPQ	255
14.11.2 Supply Voltage and Plug Configurations	255
14.12 Spanish Standards	
14.12.1 AEE	256
14.12.2 AENC	256
14.12.3 Supply Voltages and Plug Configurations	256

14. CONTINENTAL EUROPE (CONT)

CONTENTS

ITEM	PAGE
14.13 Swedish Standards	
14.13.1 SEMKO	257
14.13.2 ITS	257
14.13.3 Supply Voltage and Plug Configurations	257
14.14 Swiss Standards	
14.14.1 SNV	258
14.14.2 PTT	258
14.14.3 TZV VS	259
14.14.4 SEV	259
14.14.5 Supply Voltage and Plug Configurations	259

14. CONTINENTAL EUROPE

14.1 European Union (EU) Standards

14.1.1 CENELEC

European Committee for Electrotechnical Standardization
2 rue Brederode 1000
Brussels, Belgium
Tel: 32-2-550-0811

DOCUMENT NO.	TITLE
EN 50020	Intrinsically Safe Electrical Apparatus
HD 21	PVC Insulated Wire & Cable
HD 22	Rubber Insulated Cables of Rated Voltages Up To and Including 450/750 V
HD 359	Flexible Elevator Cables

CENELEC has adopted common standards so the European community would have certain types of compatible cable. CENELEC adopts existing IEC standards whenever possible. As a result, HD-21 and HD-22 CENELEC committee documents are based on relevant IEC specifications. The member countries adopt these standards without any fundamental changes. Each country's testing authority can do its own testing for a manufacturer to obtain **HAR** (Harmonized) approval.

For example, in Germany the established specifications have been published as:

- DIN 57281/VDE 0281
Specification for wire and cable for power circuits with thermoplastic insulation based on PVC.
- DIN 57282/VDE 0282
Specification for wire and cable for power circuits with rubber insulation.

German regulations in VDE 0250 refer to wire and cable which has been replaced by newer types complying with the harmonized regulations. The older types are no longer standard in the industry.

The countries in Table 14.1 are permanent CENELEC members that recognize the **HAR** mark. When wire and cable is manufactured in a CENELEC country and is marked with the **HAR approval** on the jacket, it may be used interchangeably in the member countries.

The **HAR** identification mark is applied along with the marks of origin and testing authority, to at least one conductor or the outer jacket. For example, Siemens products are marked: **SIEMENS** <VDE> <HAR>. In addition, there are country identification threads which are colored Black, Red, and Yellow. The different lengths of the colors indicate the nationality of the testing authority. For example, Black 3 cm (1.2 inches) long, Red 1 cm (0.4 inches) long, and Yellow 1 cm (0.4 inches) long, indicates Germany.

Table 14.1—CENELEC harmonized approvals in the European Union

CENELEC MEMBER COUNTRY	Licensing Body/ Certification Agency	Harmonized Marks (Imprint or Embossing on Jacket or Insulation)	Harmonized Marks (Black-Red-Yellow Identification Thread on Inside of Jacket)					
			Black		Red		Yellow	
			Inches	cm	Inches	cm	Inches	cm
Austria	Österreichischer Verband für Elektrotechnik (ÖVE)	<ÖVE> <HAR>	1.181	3	0.394	1	1.969	5
Belgium	Comité Electrotechnique Belge (CEBEC)	CEBEC <HAR>	0.394	1	1.181	3	0.394	1
Denmark	Danmarks Elektriske Materielkontroll	<DEMKO> <HAR>	1.181	3	0.394	1	1.181	3
France	Union Technique de l'Electricité (UTE)	UTE <HAR>	1.181	3	1.181	3	0.394	1
Germany	Verband Deutscher Elektrotechniker (VDE)	<VDE> <HAR>	1.181	3	0.394	1	0.394	1
Ireland	National Standards Authority of Ireland (NSAI)	<IIRS> <HAR>	1.181	3	1.181	3	1.969	5
Italy	Istituto Italiano del Marchio de Qualita (IMQ)	IEMMEQU <HAR>	0.394	1	1.181	3	1.969	5
Netherlands	N.V. tot Keuring van Elektrotechnische Materialen (KEMA)	KEMA-KEUR <HAR>	0.394	1	1.181	3	1.181	3
Norway	Norges Elektriske Materielkontroll (NEMKO)	<NEMKO> <HAR>	0.394	1	0.394	1	2.756	7
Spain	Asociación Electrotécnica y Electrónica Española (AEE)	◇UNE◇ <HAR>	1.181	3	0.394	1	2.756	7
Sweden	Svenska Elektriska Materielkontrollanstalter (SEMKO)	<SEMKO> <HAR>	0.394	1	0.394	1	1.963	5
United Kingdom	British Approvals Service for Electric Cables	BASEC <HAR>	0.394	1	0.394	1	1.181	3

14. CONTINENTAL EUROPE

14.1.2 CENELEC Cable Identification

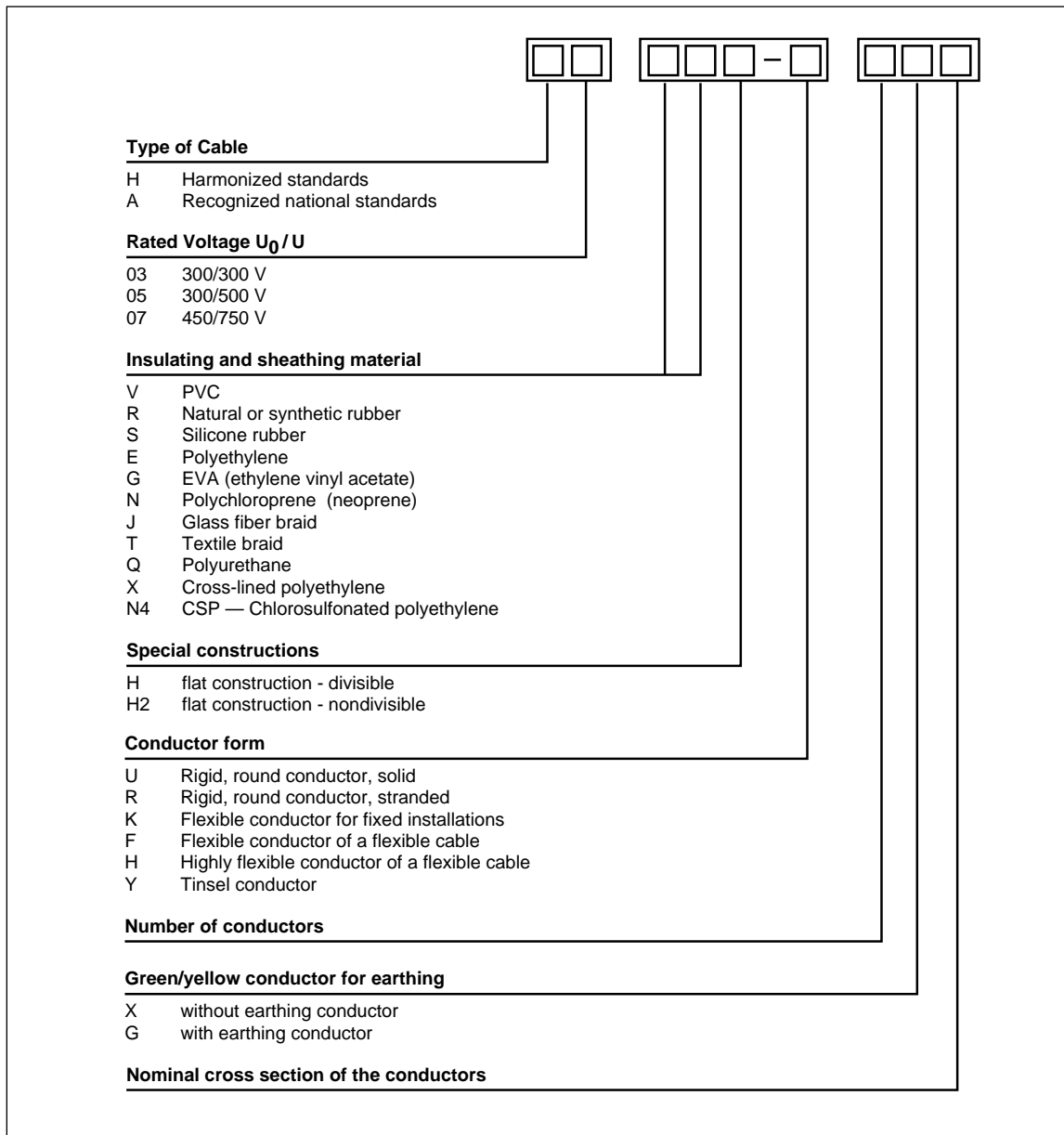

Figure 14.1—CENELEC cable identification code

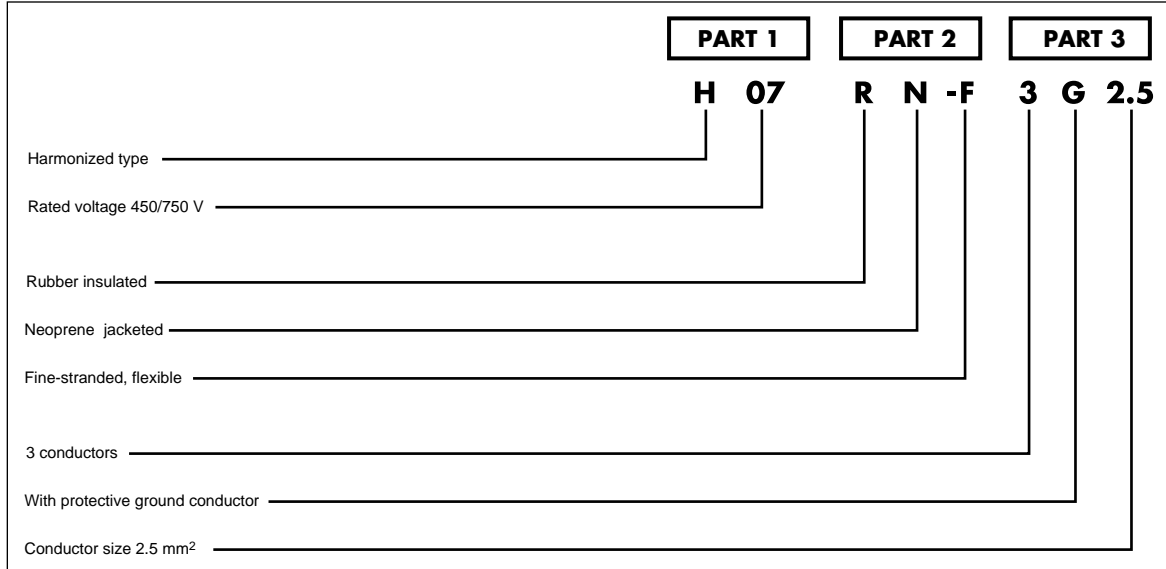

Figure 14.2—Example of a CENELEC cable identification code

Below are CENELEC identification codes for some common harmonized cable types:

CENELEC HARMONIZED ID CODE

- H03VH-H PVC Flexible Figure “8” Cable
- H03VV-F2 PVC/PVC Flexible Mains Cable, 300 V, 2 Core
- H03VV-F3 PVC/PVC Flexible Mains Cable, 300 V, 3 Core
- H03VVH2-F2 PVC/PVC Flexible Mains Cable, 300 V, 2 Core Oval
- H05RR-F2 Rubber/Rubber Flexible Mains Cable, 300/500 V, 2 Core
- H05RR-F3 Rubber/Rubber Flexible Mains Cable, 300/500 V, 3 Core
- H05RR-F4 Rubber/Rubber Flexible Mains Cable, 300/500 V, 4 Core
- H05RR-F5 Rubber/Rubber Flexible Mains Cable, 300/500 V, 5 Core
- H05V-U PVC Single Conductor Building Wire, 450/750 V
- H05VV-F2 PVC/PVC Flexible Mains Cable, 300/500 V, 2 Core
- H05VV-F3 PVC/PVC Flexible Mains Cable, 300/500 V, 3 Core
- H05VV-F4 PVC/PVC Flexible Mains Cable, 300/500 V, 4 Core
- H05VV-F5 PVC/PVC Flexible Mains Cable, 300/500 V, 5 core
- H07V-K PVC Appliance Wire, 450/750 V, Single Conductor
- H07V-R PVC Single Conductor Building Wire, 450/750 V
- H07V-U PVC Single Conductor Building Wire, 450/750 V, Solid Copper
- H05VVH2-F Flat Flexible Elevator Cable

14. CONTINENTAL EUROPE

14.1.3 CENELEC Color Codes

Through CENELEC, the EU countries have established the following color code systems. "Green/yellow" indicates green insulation with a yellow stripe:

• **FOR FLEXIBLE CABLES:**

1 conductor	all colors except yellow, green, white or grey
2 conductor	brown and light blue
3 conductor	green/yellow, brown and light blue
4 conductor	green/yellow, black, light blue and brown
5 conductor	green/yellow, black, light blue, brown and black
>5 conductors	one conductor green/yellow (placed in the outer layer), the other ones black with white number

• **FOR FIXED INSTALLATIONS WITHOUT A GREEN/YELLOW EARTH CONDUCTOR:**

1 conductor	all colors except yellow, green, white or grey
2 conductor	black and light blue
3 conductor	black, light blue and brown
4 conductor	black, light blue, brown and black
5 conductor	black, light blue, brown, black and black
>5 conductors	all conductors black with white numbers

• **FOR FIXED INSTALLATIONS WITH A GREEN/YELLOW EARTH CONDUCTOR:**

1 conductor	all colors except yellow, green, white or grey
2 conductor	light blue and black
3 conductor	green/yellow, black and light blue
4 conductor	green/yellow, black, light blue and brown
5 conductor	green/yellow, black, light blue, brown and black
>5 conductors	one conductor green/yellow (placed in the outer layer), the other ones black with white numbers

14.1.4 CENELEC Copper Conductors

In the EU, the number of wires in a conductor (the fineness of the strand) is indicated by a numeral instead of by a letter as with the U.S. system. For example, a Class 6 conductor has more wires than a Class 5. Tables 14.2 through 14.5 give the DC resistance for some common conductor sizes and stranding types.

Table 14.2—DC resistance of Class 1 (solid) copper conductors

NOMINAL CONDUCTOR SIZE	MINIMUM NUMBER OF WIRES	APPROXIMATE DIAMETER OF WIRE	MAXIMUM DC RESISTANCE AT 20°C
		mm	ohms/km
mm ²			
1.5	1	1.38	12.10
2.5	1	1.78	7.41
4	1	2.25	4.61
6	1	2.76	3.08
10	1	3.57	1.83
16	1	4.50	1.15
25	1	5.65	0.727
35	1	6.60	0.524

Table 14.3—DC resistance and stranding of Class 2 copper conductors

NOMINAL CONDUCTOR SIZE	MINIMUM NUMBER OF WIRES		MAXIMUM DC RESISTANCE AT 20°C
	CIRCULAR	COMPACT CIRCULAR OR SECTOR SHAPED	
mm ²			ohms/km
1.5	7	—	12.10
2.5	7	—	7.41
4	7	—	4.61
6	7	—	3.08
10	7	—	1.83
16	7	6	1.15
25	7	6	0.727
35	7	6	0.524
50	19	6	0.387
70	19	12	0.268
95	19	15	0.193
120	37	18	0.153

Continued

14. CONTINENTAL EUROPE

Table 14.3—DC resistance and stranding of Class 2 copper conductors

Continued

NOMINAL CONDUCTOR SIZE	MINIMUM NUMBER OF WIRES		MAXIMUM DC RESISTANCE AT 20°C
	CIRCULAR	COMPACT CIRCULAR OR SECTOR SHAPED	
mm ²			ohms/km
150	37	18	0.124
185	37	30	0.0991
240	61	34	0.0754
300	61	34	0.0601
400	61	53	0.0470
500	61	53	0.0366
630	91	53	0.0283
800	91	53	0.0221
1,000	91	53	0.0176

Table 14.4—DC resistance and stranding of Class 5 (flexible) copper conductors

NOMINAL CONDUCTOR SIZE	MAXIMUM DIAMETER OF WIRES	MAXIMUM DC RESISTANCE AT 20°C	
		PLAIN COPPER	TINNED COPPER
mm ²	mm	ohms/km	ohms/km
0.5	0.21	39	40.1
0.75	0.21	26	26.7
1	0.21	19.5	20
1.5	0.26	13.3	13.7
2.5	0.26	7.98	8.21
4	0.31	4.95	5.09
6	0.31	3.30	3.39
10	0.41	1.91	1.95
16	0.41	1.21	1.24
25	0.41	0.780	0.795
35	0.41	0.554	0.565
50	0.41	0.386	0.393
70	0.51	0.272	0.277
95	0.51	0.206	0.210
120	0.51	0.161	0.164

Continued



14. CONTINENTAL EUROPE

Table 14.4–DC resistance and stranding of Class 5 (flexible) copper conductors

Continued

NOMINAL CONDUCTOR SIZE	MAXIMUM DIAMETER OF WIRES	MAXIMUM DC RESISTANCE AT 20°C	
		PLAIN COPPER	TINNED COPPER
mm ²	mm	ohms/km	ohms/km
150	0.51	0.129	0.132
185	0.51	0.106	0.108
240	0.51	0.0801	0.0817
300	0.51	0.0641	0.0654
400	0.51	0.0486	0.0495
500	0.61	0.0384	0.0391

Table 14.5–DC resistance and stranding of Class 6 (highly flexible) copper conductors

NOMINAL CONDUCTOR SIZE	MAXIMUM DIAMETER OF WIRES	MAXIMUM DC RESISTANCE AT 20°C	
		PLAIN COPPER	TINNED COPPER
mm ²	mm	ohms/km	ohms/km
0.5	0.16	39	40.1
0.75	0.16	26	26.7
1	0.16	19.5	20
1.5	0.16	13.3	13.7
2.5	0.16	7.98	8.21
4	0.16	4.95	5.09
6	0.21	3.30	3.39
10	0.21	1.91	1.95
16	0.21	1.21	1.24
25	0.21	0.780	0.795
35	0.21	0.554	0.565
50	0.31	0.386	0.393
70	0.31	0.272	0.277
95	0.31	0.206	0.210
120	0.31	0.161	0.164

Continued

14. CONTINENTAL EUROPE

Table 14.5–DC resistance and stranding of Class 6 (highly flexible) copper conductors

Continued

NOMINAL CONDUCTOR SIZE	MAXIMUM DIAMETER OF WIRES	MAXIMUM DC RESISTANCE AT 20°C	
		PLAIN COPPER	TINNED COPPER
mm ²	mm	ohms/km	ohms/km
150	0.31	0.129	0.132
185	0.31	0.106	0.108
240	0.31	0.0801	0.0817
300	0.31	0.0641	0.0654

14.1.5 CEN



European Committee for Standardization
2 rue Brederode 1000, Brussels, Belgium
Tel: 32-2-550-0811

14.1.6 Supply Voltages and Plug Configurations

Table 14.6–EU supply voltages

FREQUENCY (Hz)	VOLTAGE
50	220
50	250

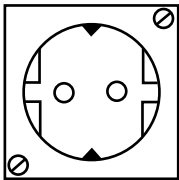
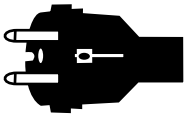
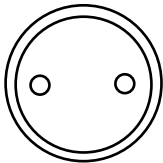
Table 14.7–EU power plug configurations

Jack	Plug	Description
		“Schuko” European CEE 7
		Ungrounded Eurocord CEE 7/16

14.2 Austrian Standards

14.2.1 ÖVE
 Österreichischer Verband Für Elektrotechnik
 Vienna
 Austria
 Tel: 43-1-587-6373
 Fax: 43-1-586-7408



14.2.2 Supply Voltage and Plug Configuration

Table 14.8–Austrian supply voltage

FREQUENCY (Hz)	VOLTAGE
50	220/380

The neutral wire of the secondary distribution system is grounded. A grounding conductor is required in the electrical cord attached to appliances that are not double insulated.

Table 14.9–Austrian plug configuration

Jack	Plug	Description
		“Schuko” European CEE 7

14. CONTINENTAL EUROPE

14.3 Belgian Standards

14.3.1 CEBEC

Comité Electrotechnique Belge
Brussels
Belgium
Tel: 32-2-556-0020
Fax: 32-2-556-0034



14.3.2 IBN/NBT

Institut Belge de Normalisation
Rue Van Orley, 5
1000 Bruxelles
Belgium
Tel: 32-2-217-2459
Fax: 32-2-223-1188

DOCUMENT NO.	TITLE
NBN C.33.111	Armored cables insulated with impregnated paper for the transmission and distribution of electrical energy.
NBN 146	Lead-sheathed, paper-insulated telephone and signaling cables for industrial and private networks.
NBN C.33.112	Lead-sheathed, armored, paper-insulated cables for networks rated from 25 to 75 kV.
NBN C.33.121	Armored, PVC insulated cables for the transmission and distribution of electrical energy.
NBN 751	Armored, polyethylene insulated cables for telephone networks.
NBN 759	Armored, PVC insulated cables for signaling networks.
NBN C.33.221	Armored, aluminum conductor, PVC insulated cables for the transmission and distribution of electrical energy.
NBN C.33.321	Insulated, preassembled aerial conductors for low voltage distribution and branch circuits.
NBN C.33.211	Armored, aluminum conductor cables insulated with impregnated paper for the transmission and distribution of electrical energy.
NBN C.33.322	PVC and XLP cables for the transmission and distribution of electrical energy.
NBN C.33.222	PVC insulated cable assemblies with noninsulated neutral for the transmission and distribution of electrical energy.
NBN 10	Stranded cables insulated with rubber.
NBN 10.01	Flexible cables insulated with rubber.
NBN 458.01	Flexible cables insulated with PVC.



14.3.3 Supply Voltages and Plug Configurations

Table 14.10–Belgian supply voltages

FREQUENCY (Hz)	VOLTAGE
50	127/220
50	220/380

The neutral wire of the secondary distribution system is grounded. A grounding conductor is required in the electrical cord attached to appliances.

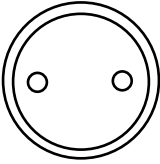
Table 14.11–Belgian plug configurations

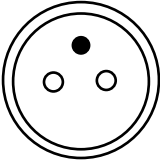
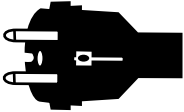
Jack	Plug	Description
		Ungrounded Eurocord CEE 7/16
		Belgium Socket CEE 7/7 plug

14. CONTINENTAL EUROPE

14.4 Danish Standards

14.4.1 DEMKO
Danmarks Elektriske Materielkontrol
Copenhagen
Denmark
Tel: 45-4-494-7266





14.4.2 Supply Voltage and Plug Configuration

Table 14.12–Danish supply voltage

FREQUENCY (Hz)	VOLTAGE
50	220/380

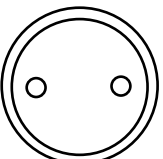
Table 14.13–Danish plug configuration

Jack	Plug	Description
		Ungrounded Eurocord CEE 7/16

14.5 French Standards

14.5.1 UTE

Union Technique de l'Electricité
Immeuble Lavoisier
92052 Paris La Defense Cedex
France
Tel: 33-1-46-91-11-11
Fax: 33-1-47-89-47-75



DOCUMENT NO.	TITLE
NF C32-207	Insulated Cables Covered with a Light PVC Sheath and Rated 300/500 V
NF C33-209	Cable Assemblies for Overhead Systems Rated 0.6/1 kV

14.5.2 AFN

Association Française de Normalisation
Tour Europe
CEDEX 7
92080 Paris La Defense
France

14.5.3 CIGRE

Conference International des Grands Reseaux
Electriques a Haute Tension
3-5 Rue de Metz
F-75010 Paris
France
Tel: 33-1-42-46-50-85
Fax: 33-1-42-46-58-27

14.5.4 CNET

DOCUMENT NO.	TITLE
DEC-0611/C	Smoke Corrosiveness Test



14. CONTINENTAL EUROPE

14.5.5 Supply Voltages and Plug Configurations

Table 14.14–French supply voltages

FREQUENCY (Hz)	VOLTAGE
50	220/230 127/220

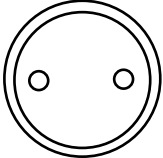
Table 14.15–French plug configurations

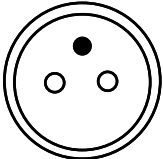
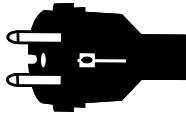
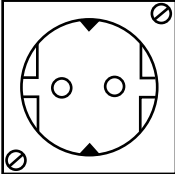
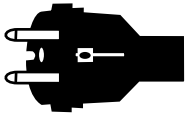
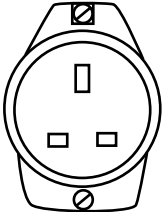
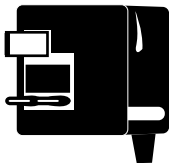
Jack	Plug	Description
		Ungrounded Eurocord CEE 7/16
		French Socket CEE 7/7 plug
		“Schuko” European CEE 7
		British Standard BS 1363

14.6 German Standards

14.6.1 DIN

Deutsches Institut für Normung
Burggrafenstrasse 6
D-10787 Berlin
Germany
Tel: 49-30-260-10
Fax: 49-30-260-11231

DOCUMENT NO.	TITLE
0888	Optical Waveguides for Telecommunication Systems

Table 14.16—DIN 47100 color code for single conductors

CONDUCTOR NO.	COLOR	CONDUCTOR NO.	COLOR	
1	45	white	23	white/red
2	46	brown	24	brown/red
3	47	green	25	white/black
4	48	yellow	26	brown/black
5	49	grey	27	grey/green
6	50	pink	28	yellow/green
7	51	blue	29	pink/green
8	52	red	30	yellow/pink
9	53	black	31	green/blue
10	54	violet	32	yellow/blue
11	55	grey/pink	33	green/red
12	56	red/blue	34	yellow/red
13	57	white/green	35	green/black
14	58	brown/green	36	yellow/black
15	59	white/yellow	37	grey/blue
16	60	yellow/brown	38	pink/blue
17	61	white/grey	39	grey/red
18		grey/brown	40	pink/red
19		white/pink	41	grey/black
20		pink/brown	42	pink/black
21		white/blue	43	blue/black
22		brown/blue	44	red/black

14. CONTINENTAL EUROPE

Table 14.17–DIN 47100 color code for paired conductors

PAIR NO.			WIRE A	WIRE B
1	23	45	white	brown
2	24	46	green	yellow
3	25	47	grey	pink
4	26	48	blue	red
5	27	49	black	violet
6	28	50	grey/pink	red/blue
7	29	51	white/green	brown/green
8	30	52	white/yellow	yellow/brown
9	31	53	white/grey	grey/brown
10	32	54	white/pink	pink/brown
11	33	55	white/blue	brown/blue
12	34		white/red	brown/red
13	35		white/black	brown/black
14	36		grey/green	yellow/grey
15	37		pink/green	yellow/pink
16	38		green/blue	yellow/blue
17	39		green/red	yellow/red
18	40		green/black	yellow/black
19	41		grey/blue	pink/blue
20	42		grey/red	pink/red
21	43		grey/black	pink/black
22	44		blue/black	red/black

14.6.2 VDE

**Verband Deutscher Elektrotechniker
(German Electrotechnical Society)
Merianstrasse 29
D-63069 Offenbach (Frankfurt), Germany
Tel: 49-69-840-0060
Fax: 49-69-840-00655**



DOCUMENT NO.	TITLE
VDE 0472 part 813	Corrosivity of combustion gases
VDE 0281	Wire and cable for power circuits with thermoplastic insulation based on PVC
VDE 0282	Wire and cable for power circuits with rubber insulation
VDE 0293	Identification of conductors in cables and flexible cords used in power installations rated up to 1,000 V
VDE 0295	Conductors of cables, wires, and flexible cords for power installation

14.6.3 DKE



Deutsche Elektrotechnische
Kommission im DIN und VDE
Stresemannallee 15
D-60596 Frankfurt 70
Germany
Tel: 49-69-630-80
Fax: 49-69-630-8273

14.6.4 Supply Voltage and Plug Configurations

Table 14.18—German supply voltage

FREQUENCY (Hz)	VOLTAGE
50	220/380

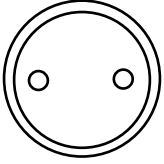
Table 14.19—German plug configurations

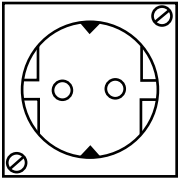
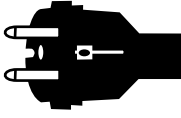
Jack	Plug	Description
		Ungrounded Eurocord CEE 7/16
		“Schuko” European CEE 7

14. CONTINENTAL EUROPE

14.7 Irish Standards

14.7.1 NSAI

National Standards Authority of Ireland
FORBAIRT - Glasnevin
Dublin 9
Ireland
Tel: 353-1-837-0101
Fax: 353-1-857-0441

14.7.2 Supply Voltage and Plug Configurations

Table 14.20–Irish supply voltage

FREQUENCY (Hz)	VOLTAGE
50	220/380

The neutral wire of the secondary distribution system is grounded. A grounding conductor is required in the electrical cord attached to appliances.

Table 14.21–Irish plug configurations

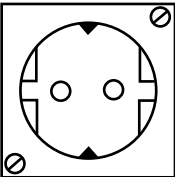
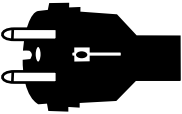
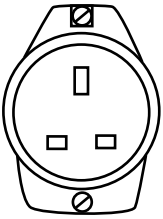
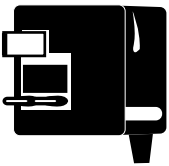
Jack	Plug	Description
		“Schuko” European CEE 7
		British Standard BS 1363

14.8 Italian Standards

14.8.1 IMQ

Istituto Italiano del Marchio de Qualita
Via Quintiliano, 43
20L38 Milano
Italy
Tel: 39-2-50731
Fax: 39-2-5073271



14.8.2 CEI

Comitato Tecnico Italiano
Viale Monza 259
20L56 Milano
Italy
Tel: 39-02-257-731
Fax: 39-2-25-773-210

14.8.3 CESI

Centro Elettrotecnico Sperimentale Italiano
Via Rubbattino 54
20134 Milano
Italy
Tel: 39-2-212-5340
Fax: 39-2-212-5481

14.8.4 UNEL

Unificazione Electretechnia

14. CONTINENTAL EUROPE



14.8.5 Supply Voltage and Plug Configurations

Table 14.22–Italian supply voltage

FREQUENCY (Hz)	VOLTAGE
50	220/380

A grounding conductor is required in the electrical cord attached to appliances. The neutral wire of the secondary distribution system is grounded. Frequency tolerance: $\pm 2\%$; voltage tolerance: $\pm 10\%$.

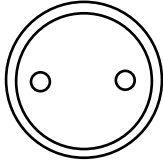
Table 14.23–Italian plug configurations

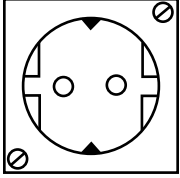
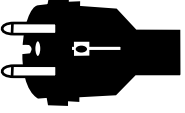
Jack	Plug	Description
		Ungrounded Eurocord CEE 7/16
		“Schuko” European CEE 7

14.9 Dutch Standards

14.9.1 KEMA

N.V. tot Keuring van Elektrotechnische Materialen
 Utrechtseweg 310
 6812 AR Arnhem
 Post Office Box 9035
 6800 ET Arnhem
 Netherlands
 Tel: 31-85-56-91-11
 Fax: 31-85-51-56-06



14.9.2 NEC

Netherlands Electro-Technical Committee
Post Office Box 5059
2600 Delft
Netherlands
Tel: 31-15-690-128
Fax: 31-15-690-242





14.9.3 Supply Voltage and Plug Configurations

Table 14.24 –Dutch supply voltage

FREQUENCY (Hz)	VOLTAGE
50	220/380

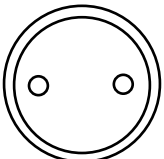
The neutral wire of the secondary distribution system is grounded.

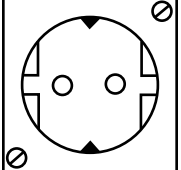
Table 14.25 –Dutch plug configurations

Jack	Plug	Description
		Ungrounded Eurocord CEE 7/16
		“Schuko” European CEE 7

14. CONTINENTAL EUROPE

14.10 Norwegian Standards

14.10.1 NEMKO

Norges Elektriske Materiellkontroll
0371 Oslo
Norway
Tel: 47-2-296-0330
Fax: 47-2-296-8636



14.10.2 NTRA



Post Office Box 2592 Solli
0203 Oslo 2
Norway
Tel: 47-2-926-675
Fax: 47-2-441-177

14.10.3 Supply Voltage and Plug Configurations

Table 14.26–Norwegian supply voltage

FREQUENCY (Hz)	VOLTAGE
50	230

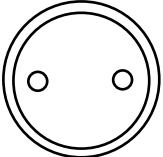
Table 14.27–Norwegian plug configurations

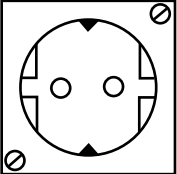
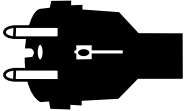
Jack	Plug	Description
		Ungrounded Eurocord CEE 7/16
		“Schuko” European CEE 7

14.11 Portuguese Standards

14.11.1 IPQ



Instituto Portugues da Qualidade
 Rue José Estevao, 83 A
 1199 Lisboa Codex
 Portugal
 Tel: 351-1-52-3978
 Fax: 351-1-53-0033

14.11.2 Supply Voltage and Plug Configurations

Table 14.28 –Portuguese supply voltage

FREQUENCY (Hz)	VOLTAGE
50	230/380

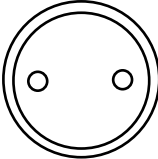
Table 14.29 –Portuguese plug configurations

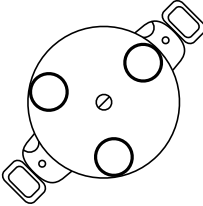
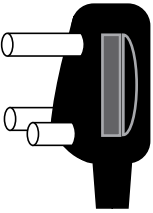
Jack	Plug	Description
		Ungrounded Eurocord CEE 7/16
		Old British Standard BS 546

14. CONTINENTAL EUROPE

14.12 Spanish Standards

14.12.1 AEE

Asociación Electrotécnica y Electrónica Española
Spain



14.12.2 AENC

Asociación Española de Normalización y Certificación
Fernandez de la Hoz 52
28010 Madrid
Spain
Phone: 34-1-310-4961
Fax: 34-1-140-4976



14.12.3 Supply Voltages and Plug Configurations

Table 14.30—Spanish supply voltages

FREQUENCY (Hz)	VOLTAGE
50	127/220 220/380

A grounding conductor is required for the 220/380 voltage.

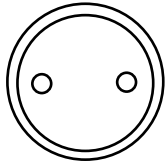
Table 14.31—Spanish plug configurations

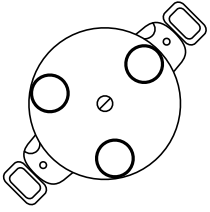
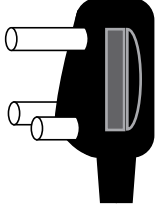
Jack	Plug	Description
		Ungrounded Eurocord CEE 7/16
		Old British Standard BS 546

14.13 Swedish Standards

14.13.1 SEMKO

Svenska Elektriska Materiel Kontrollanstalten
Box 1103
S-16422 Kista
Sweden
Tel: 46-8-750-0000
Fax: 46-8-750-0303



14.13.2 ITS

Information Technology Standardization
Electrum 235
16440 Kista
Sweden
Phone: 46-8-793-9000
Fax: 46-8-751-5363

14.13.3 Supply Voltage and Plug Configurations

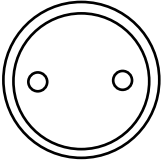

Table 14.32—Swedish supply voltage

FREQUENCY (Hz)	VOLTAGE
50	230/380

The neutral wire of the secondary distribution system is grounded. A grounding conductor is required in the electrical cord attached to appliances.

14. CONTINENTAL EUROPE

Table 14.33—Swedish plug configurations

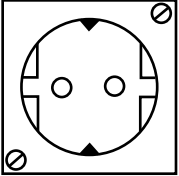
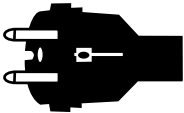
Jack	Plug	Description
		Ungrounded Eurocord CEE 7/16
		“Schuko” European CEE 7

14.14 Swiss Standards

14.14.1 SNV

Schweizerische Normen Vereinigung
(Swiss Standards Association)
Postfach
8032 Zurich
Switzerland
Tel: 41-1-254-5454
Fax: 41-1-254-5474



14.14.2 PTT

Swiss Postal and Telephone Agency
3030 Bern
Switzerland

DOCUMENT NO.

TITLE

844.13

Standard for the Fabrication and Delivery of Hookup Wire and Standardized Communication Cable

14.14.3 TZV VS

Fachgremium für Technische Normierung
 3000 Berne 29
 Switzerland
 Phone: 41-31-622-713
 Fax: 41-31-625-747

14.14.4 SEV

Schweizerischer Elektrotechnischer Verein
 Switzerland



14.14.5 Supply Voltage and Plug Configurations

Table 14.34 – Swiss supply voltage

FREQUENCY (Hz)	VOLTAGE
50	220/380

The neutral wire of the secondary distribution system is grounded. A grounding conductor is required in the electrical cord attached to appliances.

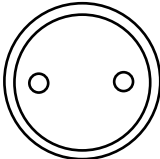
Table 14.35 – Swiss plug configurations

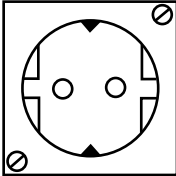
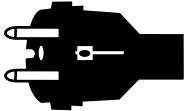
Jack	Plug	Description
		Ungrounded Eurocord CEE 7/16
		“Schuko” European CEE 7