

TELUS

TELUS has standardized on Transition Networks' ION Platform because of its flexibility, high performance, easy installation, and secure management capabilities. This multi-service integration solution provides TELUS customers with the connectivity they need and the network throughput they desire.

Company Type: Canadian Communications Services Provider

Headquarters: Vancouver, Canada

Transition Networks Product Deployed: [The ION Platform](#)

Customer Overview

TELUS is Canada's fastest-growing nationwide telecommunications company, with 12.5 million subscriber connections, including 8.4 million wireless subscribers, 1.6 million high-speed Internet subscribers, 1.4 million residential network access lines and 1 million TELUS TV customers. TELUS provides a wide range of communications products and services, including wireless, data, Internet Protocol (IP), voice, television, entertainment and video, and is Canada's largest healthcare IT provider.

Customer Challenges

Recently, TELUS had been utilizing multiple vendors' equipment to provide customers with business Ethernet and enterprise data services. This complicated network maintenance created challenges with troubleshooting, required more network infrastructure equipment inventory, and made vendor management more complex.

TELUS needed to simplify their service operations in order to gain more control over their networks. To address this challenge, the national Canadian service provider conducted an extensive evaluation of vendors and solutions that could allow them to simplify service operations and gain more control over their network by standardizing on a single network platform and consolidating vendors.

Customer Solution

As a result of the intelligent and comprehensive evaluation, TELUS streamlined vendors and standardized its business Ethernet and enterprise network services by selecting Transition Networks' [ION Platform](#). The ION Platform was determined to be the ideal network solution for its management capabilities, security of data, and ability to integrate multiple services into one common chassis. In addition to reducing costs by consolidating vendors and standardizing platforms, TELUS was able to simplify setup and ongoing maintenance because technicians now have in-depth knowledge of a universal equipment platform.

The ION Platform is built to meet the connectivity demands of today's networks with room to grow for future upgrades. The ION Platform integrates DS1/DS3 services and various rates of Ethernet service into one secure, managed platform. By combining all services into one universal platform with remote end-to-end management.

The ION Platform optimizes the network for flexible and scalable connectivity network-wide, offering lower operating expenditures while reducing capital expenses.

“Transition Networks’ ION Platform was selected because it consolidates our enterprise network services along with newer business Ethernet services into one easy-to-install platform. It has simplified and reduced our time to turn up new customer service orders, and it has also streamlined vendor management for more efficient operations and cost savings. The same equipment used in the central office (CO) is used at the customer premise. This reduces our inventory levels and increases technician familiarity with products, allowing them to install, test, and turn up customer services faster.”

—Rob Keates: Manager IP Optical Standards for TELUS

Available in either 1RU or 2RU modular chassis with 1, 2, 6 or 19 slots, The ION Platform provides simple and comprehensive end-to-end management of connected network devices with strong management security authentication (TACAS+, SSH/TLS) allowing only a single “trusted” point of entry into the network. It offers a variety of flexible services including redundant optical networking over single or duplex fiber, dense or coarse wavelength division multiplexing (WDM) utilizing multiple wavelengths over an existing fiber link, tiered bandwidth rate limiting, and the ability to hand off either copper, fiber, or both, depending on the end-customer network equipment requirements.

The ION Product Family



19-Slot



6-Slot



1-Slot



2-Slot

Other key features include:

- Redundant instant failover power supplies with remote sensing for fans, temperature and power
- Universal system modules for chassis used at CO and customer site or anywhere in the network
- End-to-end remote management via a single [ION Management Module](#)

Figure 1: ION Network Application Examples

xWDM

KEY
 Fiber Optic Cable
 Copper Cable

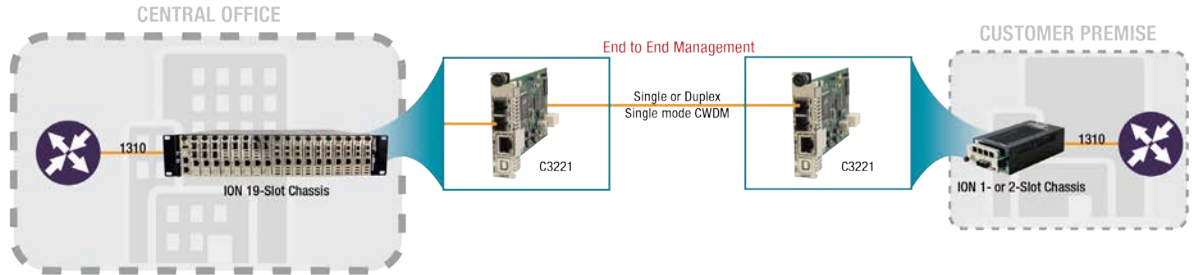

Redundancy

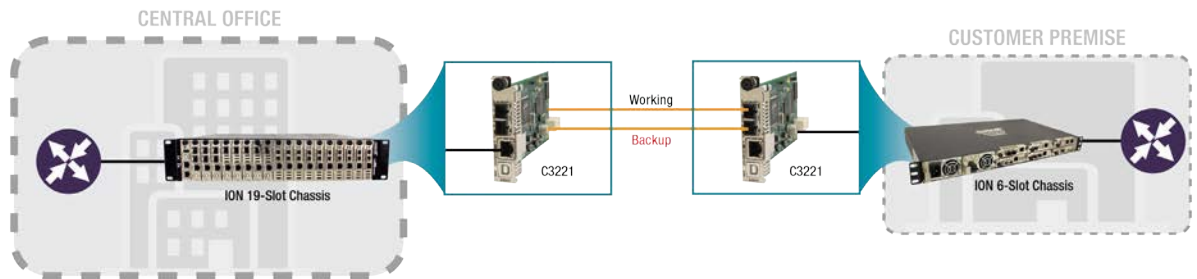

Copper or Fiber Hand-off

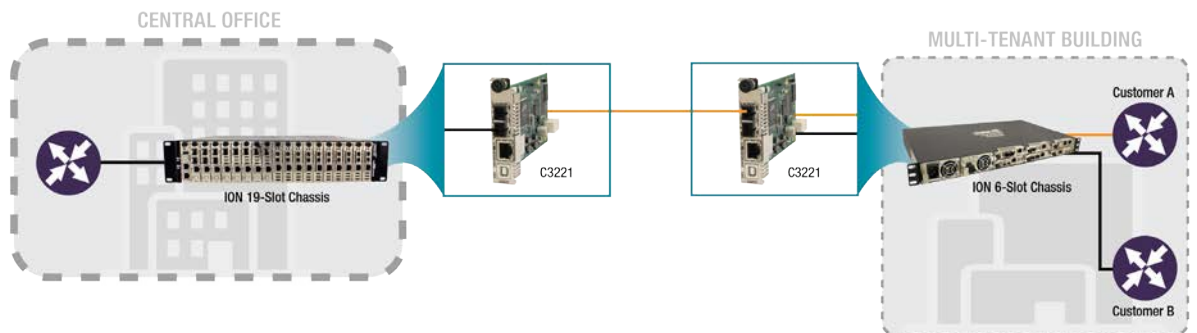

Customer Results

The ION Platform allows TELUS to provide reliable physical layer transport of multiple enterprise data services for high levels of throughput to meet their customers' demands and stringent service level agreements.

Selecting the ION Platform provides TELUS with:

- Simplified network management and maintenance
- More visibility into network equipment
- Accelerated turn-up and provisioning of new customer services
- Higher security and access controls of management data
- Lower overhead expenses and costs savings
- Quicker troubleshooting
- Easier customer setup and installation
- Streamlined vendor management
- Reduced vendor product inventory

"Transition Networks has been a reliable and trusted partner. The ION Platform has allowed us to meet our business objectives for offering high quality, reliable services that are economical and affordable to the customers we serve."

—Rob Keates: Manager IP Optical Standards for TELUS

"Carrier Ethernet-certified NIDs have added protocols and features that increase costs, said Curt Carlson, Senior Product Manager for Transition Networks. But many customers simply need managed connectivity that limits network overhead and The ION Platform fills the gap for large service providers like TELUS. These customers want to be assured that the 1G service level they are paying for is what they are actually receiving. Transition Networks has a proven track record of over 29 years helping customers integrate, optimize and expand their networks and offers lifetime warranties on all of our ION products. This, in addition to our consistent product quality, has led to our outstanding 99% customer approval rating. There are millions of Transition Networks devices installed in Enterprise, service provider and industrial Ethernet environments today, and we're very proud to continue to serve customers like TELUS."

—Curt Carlson: Senior Product Manager for Transition Networks

About Transition Networks

Transition Networks, Inc. is an industry leader with over 29 years of experience designing data network integration products that deliver the bandwidth, distance, and security demanded by today's networks while future proofing for tomorrow. Offering support for multiple protocols, any interface, and a multitude of hardware platforms, including Hardened Ethernet, Carrier Ethernet, CWDM, 1G/10G Ethernet, SFPs, PoE and PoE+, Transition Networks gives you the power to deliver and manage traffic reliably in any data network – in any application – in any environment. Based in Minneapolis, MN, Transition Networks distributes hardware-based connectivity solutions exclusively through a network of resellers in 50 countries. Transition Networks is a Communications Systems, Inc. company (NASDAQ: JCS). For more information, visit us at transition.com.